

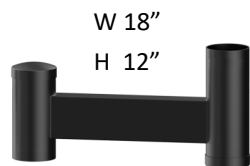

For Post Top Luminaires



W 18"
H 12"

Requires INT4 tenon on pole

CM02-E3 - 3" OD x 3" tall tenon

CM02-E4 - 4" OD x 3" tall tenon

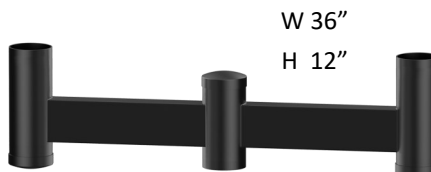

W 36"
H 12"

Requires INT4 tenon on pole

2CM02-E3 - 3" OD x 3" tall tenon

2CM02-E4 - 4" OD x 3" tall tenon



2TM02

W 40"
H 12"

Requires INT4 tenon on pole



2TM03

W 36"
H 12"

Requires INT4 tenon on pole



2TM09

W 29"
H 15"

Requires 3" OD tenon

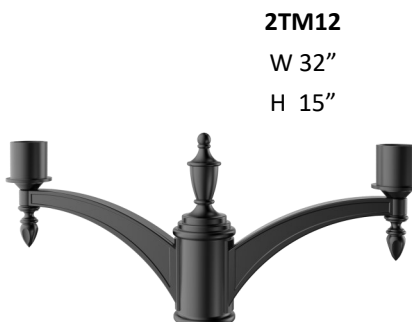

2TM12

W 32"
H 15"

Requires 3" OD tenon

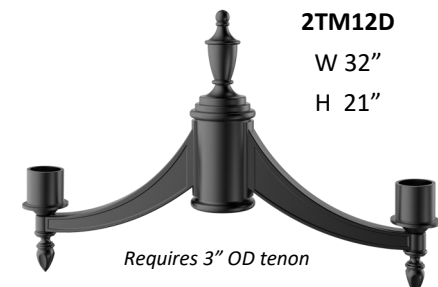

2TM12D

W 32"
H 21"

Requires 3" OD tenon

FEATURES

- Strong, lightweight and easy to install
- Cast and extruded aluminum post top mount bracket.
- Durable powder coat finish

Mounting

Installed using (6) 5/16" black oxide stainless steel set screws.

Finish

The post top mount brackets will be finished with an electrostatically applied polyester powder coat suitable for exterior use. The brackets are pretreated using industry standard environmentally responsible processes for a long lasting and durable finish.

Standard Finishes

- BK - Black (Gloss)
- BT - Black (Textured)
- SB - Statuary Bronze
- GN - Green

Premium Finishes

- WH - White (Gloss)
- CV - Copper Vein
- GV - Green Vein
- CF - Custom Finishes

Ordering Guide

	Post Top Mount Bracket	Finish
EXAMPLE	2TM09 /	BT
	CM02-E3	BK
	CM02-E4	BT
	2CM02-E3	SB
	2CM02-E4	GN
	2TM02	Premium
	2TM03	Finishes
	2TM09	WH, CV, GV, CF
	2TM12	
	2TM12D	



For Pendant Luminaires

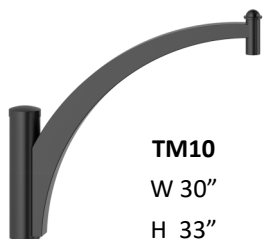

TM10
W 30"
H 33"

Requires **INT9** tenon on pole



2TM10
W 60"
H 33"

Requires **INT9** tenon on pole



CP136
W 20"
H 36"

Requires 4" OD tenon

CP136* - For use with GC6000 Series Fixtures



CP136P
W 25"
H 46"

Requires **INT9** tenon on pole

CP136P* - For use with GC6000 Series Fixtures

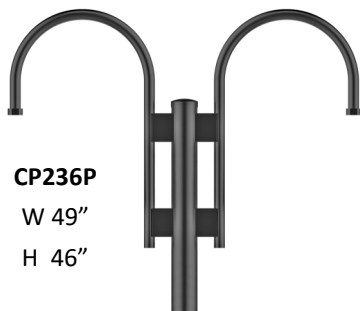

CP236P
W 49"
H 46"

Requires **INT9** tenon on pole

CP236P* - For use with GC6000 Series Fixtures



CP148
W 27"
H 48"

Requires 4" OD tenon

CP148* - For use with GC6000 Series Fixtures



CP148P
W 31"
H 48"

Requires **INT9** tenon on pole

CP148P* - For use with GC6000 Series Fixtures

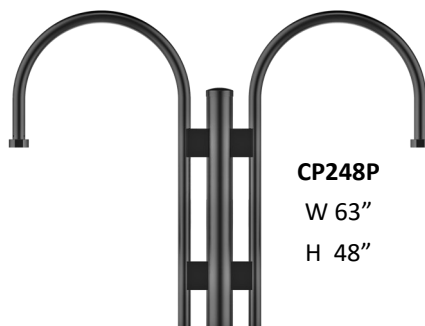

CP248P
W 63"
H 48"

Requires **INT9** tenon on pole

CP248P* - For use with GC6000 Series Fixtures

FEATURES

- Strong, lightweight and easy to install
- Cast and/or extruded aluminum post top mount bracket.
- Durable powder coat finish

Mounting

Installed using (6) 5/16" black oxide stainless steel set screws.

Finish

The post top mount brackets will be finished with an electrostatically applied polyester powder coat suitable for exterior use. The brackets are pretreated using industry standard environmentally responsible processes for a long lasting and durable finish.

Standard Finishes

- BK** - Black (Gloss)
- BT** - Black (Textured)
- SB** - Statuary Bronze
- GN** - Green

Premium Finishes

- WH** - White (Gloss)
- CV** - Copper Vein
- GV** - Green Vein
- CF** - Custom Finishes

	Post Top Mount Bracket	Finish
EXAMPLE	2TM09 /	BT
	TM10	BK
	2TM10	BT
	CP136	SB
	CP136P	GN
	CP236P	Premium
	CP148	Finishes
	CP148P	WH, CV, GV, CF
	CP248P	